

Redefining NIR based PAT!

SentroPAT Compact

The SentroPAT Compact is a flexible, robust NIR analyzer for non-destructive online monitoring of powders and granules in pharmaceutical and food manufacturing. The system provides high-value process insight during product development and robust measurements for commercial operation. This compact system builds on technological innovations from Sentronic developed over 30 years in supporting in-line analysis.

High Performance Diode Array Spectrometer

The heart of the NIR analyzer is a rugged InGaAs diode array spectrometer. High spectral resolution, high wavelength accuracy, and low noise ensure robust measurements in demanding applications. Superior system-to-system comparability simplifies method transfer between instruments. The high accuracy and comparability are complemented by superior long-term stability achieved using internal intensity and wavelength standards.

Fast Process Insights

The SentroPAT Compact is designed to be compatible with many process interfaces, such as tablet feed frames, powder blending systems, fluid bed systems as well as a variety of unit operations simulators. Internal standards ensure robust measurements even when a process is run

for days or weeks. The compact, simple design makes it easy to move the system around a manufacturing rig and get data where and when it is needed.

Flexibility and Simplicity

The focus areas of design and development were ease-of-use and maximum robustness: All optical connections are contained within the SentroPAT Compact, avoiding the need for optical cables to be run across the process environment. The internal standards can eliminate the need for primary standards to be on the process floor for system suitability checks or routine reference measurements. The internal NIR sources are designed to last the lifetime of the in-

strument. No wear parts are required to be changed by the system owner or as part of routine service. The smooth surfaces of the unit can be easily cleaned and are manufactured using materials commonly used in cGMP manufacturing environments.

Intuitive Software

The SentroPAT Compact is operated by our SentroSuite GMP software which can be installed on a dedicated PC or on any PC in the network. Many features of SentroSuite GMP software comply with commonly required aspects of 21CFR part 11 regulations. Additionally, the system can be controlled by third party interfaces such as SIPAT, SynTQ or ProaXesS.

Compact display and connection panel



Dimensions

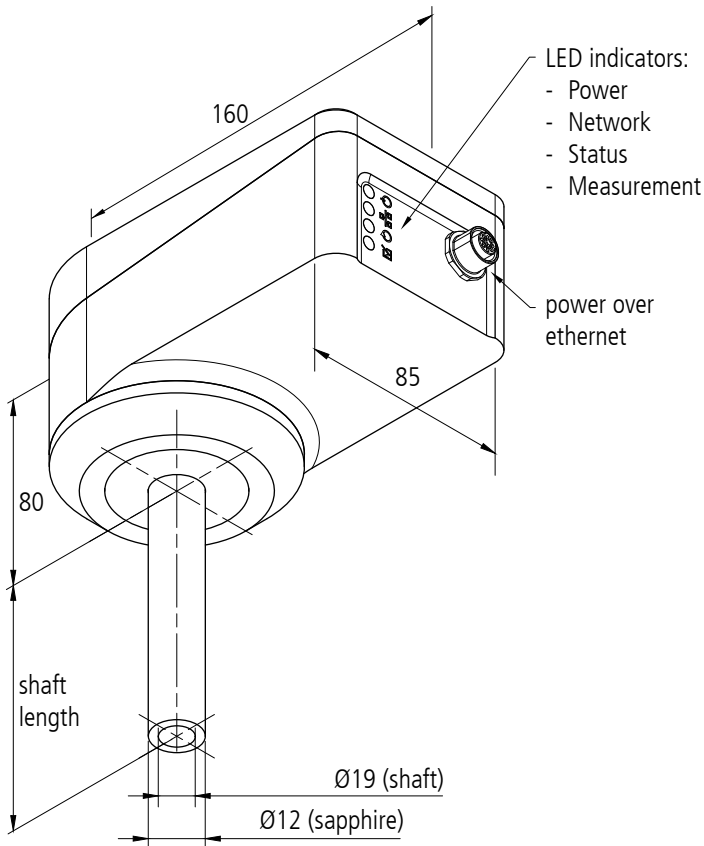

Product Versions

Product number	Product Name	Tip Length (mm)	ATEX
2530000200240	SentroPAT Compact NIR / 1100-1900 / 512 / 65	65	No
2530000100236	SentroPAT Compact NIR / 1100-1900 / 512 / 100	100	No
2530000500234	SentroPAT Compact NIR / 1100-1900 / 512 / 200	200	No
2530000300247	SentroPAT Compact NIR / 1100-1900 / 512 / 300	300	No

Technical Parameters

Spectrometer

Technology	diode array spectrometer
Wavelength range	1 100 – 1 900 nm
Spectral resolution (FWHM)	NMT10 nm

Optics / Light source

Technology	Diffuse reflectance
Measurement distance	Direct contact with sample material
Measurement diameter	ca. 5 mm
Illumination	Two integrated tungsten bulbs; expected lifetime; depending on use case ≥ 10 years
Internal reference	Amorph PTFE based intensity standard
Probe window heating	sapphire window can be heated at up to 70°C to prevent probe fouling (functionality is process dependent)

System

Embedded Controller	Linux based controller
Connections	Power over ethernet IEEE 802.3at (PoE+)
Dimensions	Housing 160 x 100 x 85 mm Probe tip $\frac{3}{4}$ " diameter; length 65; 100; 200 or 300 mm
Materials of construction	Housing Aluminium anodized Probe tip Sapphire and stainless steel 1.4404; no sealings
Mounting	Different flange designs available

Installation conditions

Temperatures	Housing 15°C – 30°C Probe tip 0°C – 80°C
Pressure rating	Probe tip 0 – 40 bar

Software

Application software	SentroSuite GMP installation on external PC
Software interface	Variety of interface options to third party software

Ratings / Classifications

System	IP65, GMP
Probe tip	FDA approved material incl. certificate
Spectroscopic	USP<(1)856>; EP 2.2.40

Sentronic GmbH

Gostritzer Strasse 63
D-01217 Dresden, Germany

Phone: + 49 (0) 351 / 8718653
e-mail: info@sentronic.eu

Sentronic US Corp.

251 Little Falls Drive
Wilmington, DE 19808, USA

Phone: +1 781-859-8483
email: info@sentronic.us.com